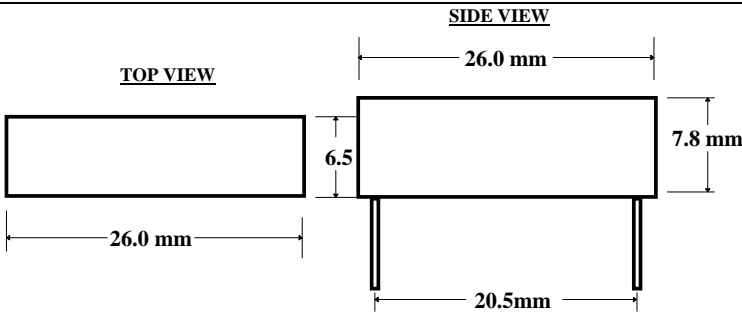
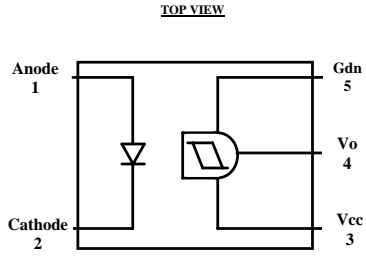

ISH3 SCHMITT TRIGGER OPTOCOUPLERS

ISOCOM[®] LTD

PACKAGES	CIRCUIT
 <p>TOP VIEW 26.0 mm 6.5 mm</p> <p>SIDE VIEW 26.0 mm 7.8 mm 20.5 mm</p>	 <p>TOP VIEW</p> <p>Anode 1 Cathode 2 Gdn 5 Vo 4 Vcc 3</p>

DESCRIPTION

The ISH 3 is an optically coupled isolator, consisting of an infrared emitting diode with a minimum separation of 15mm between the emitter and a Schmitt trigger detector. They are mounted in a sealed package, and have an operating temperature range of -40°C to +100°C with an isolation voltage of 11Kv.

Isocom Ltd supplies a multitude of plastic optocouplers for all applications varying from standard transistor optos through to Darlington and Schmitt Trigger devices. It's massive family of optos vary in speed allowing maximum opportunity to engineers worldwide.

All devices are performance guaranteed between -40°C and +100°C and have completed rigorous testing.

The Company's customers can be assured of our commitment to stringent quality, reliability and inspection standards, as demonstrated by our existing approvals. Other customer specific options can also be offered.

FEATURES

- 11000V Isolation
- Minimum internal separation of 15mm
- Low cost 5 pin package

Isocom Ltd reserves the right to change the details on this specification without notice. Please consult Isocom Ltd prior to use.

Isocom Ltd cannot accept liability for any errors or omissions.

For sales enquiries, or further information, please contact our sales office at:

Isocom Ltd, Hutton Close, Crowther Industrial Estate, District 3, Washington, NE38 0AH

Tel: +44 0191 4166 546 Fax: +44 0191 4155 055 Email Isocom@isocomptocouplers.com

Or go to the Isocom Website @: [Http://www.isocom.uk.com](http://www.isocom.uk.com)

ABSOLUTE MAXIMUM RATINGS

Storage Temperature	-40°C to +100°C
Operating Temperature	-25°C to +85°C
Lead Soldering Temperature	260°C 1.6mm from case for 5S
Input-to-Output Isolation Voltage	11000V

Input Diode

Forward DC Current	50mA	
Reverse DC Voltage	5V	
Pulse forward Current	600mA	PW. ≤100μS Repetitive Frequency =100Khz
Power Dissipation	100mW	Derate linearly above 25°C at 0.66mW/°C.

Output Detector

Supply Voltage	17V	V _{CC}
High Level Output Voltage	30V	V _{OH}
Low Level Output Voltage	50mV	I _{OL}
Low Level Output Current	-0.67mA/°C	Derate Ta >25°C
Power Dissipation	250mW	
Power Dissipation	-3.33mW	Derate Ta >25°C

ELECTRICAL CHARACTERISTICS

T_A = 25°C U.O.S. (each channel where appropriate).

Input Diode Electrical Characteristics

Parameter	Symbol	Test Conditions	Device	Min	Typ	Max	Units
Forward Voltage	V _F	I _F = 10mA		1.0	1.15	1.3	V
Reverse Current	I _R	V _R = 5V				10	μA

Output Detector Electrical Characteristics

Supply Voltage	V _{CC}			4.5		17	V
Low Level Output Voltage	V _{OL}	I _{OL} = 16mA, V _{CC} = 5V, E = 2mW/cm ²			0.07	0.4	V
High Level Output Current	I _{OH}	V _{CC} = 5V, V _{OH} = 30V, E = 0				100	μA
Supply Current Low Level	I _{CCL}	V _{CC} = 5V, E = 2mw/cm ²			2.5	5	mA
Supply Current High Level	I _{CCH}	V _{CC} = 5V, E = 0			1.2	3	mA

Coupled Electrical Characteristics

Collector-Emitter Saturation Voltage	V _{CE(Sat)}	I _C = 10μA, H = 1mW/cm ²				0.4	V
Switching Time Low- High	t _{pLH}	T _a = 25°C, V _{CC} = 5V, E = 2mw/cm ² , R _L = 280Ω			6.0		μS
Switching Time High- Low	t _{pHL}				2.0		μS
Rise Time	t _r				0.3		μS
Fall Time	t _f				0.1		μS

Isocom Ltd reserves the right to change the details on this specification without notice. Please consult Isocom Ltd prior to use.

Isocom Ltd cannot accept liability for any errors or omissions.

For sales enquiries, or further information, please contact our sales office at:

Isocom Ltd, Hutton Close, Crowther Industrial Estate, District 3, Washington, NE38 0AH

Tel: +44 0191 4166 546 Fax: +44 0191 4155 055 Email Isocom@isocomptocouplers.com

Or go to the Isocom Website @: [Http://www.isocom.uk.com](http://www.isocom.uk.com)