

TRANSISTOR OPTOCOUPLEDERS

ISOCOM[®] LTD

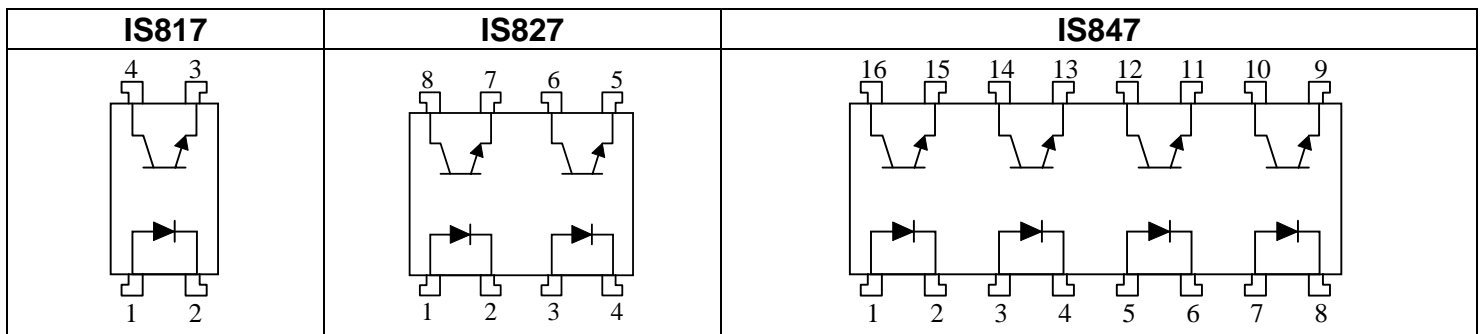

DESCRIPTION

These devices are single, dual and quad optocouplers. Each channel is composed of a Gallium Arsenide infra-red emitting diode and a silicon phototransistor. Package styles for these devices include 4 pin, 8 pin, and 16 pin, with surface mount, butt cut and gull wing options available.

The same electrical die, assembly processes and materials are used for each channel of each device shown below. Therefore absolute maximum ratings, recommended operating conditions, electrical specifications and performance characteristics are identical for all units. Any exceptions, due to packaging variations and limitations, are as noted.

Isocom Ltd supplies a multitude of plastic optocouplers for all applications varying from standard transistor optos through to Darlington's and Schmitt Trigger devices. It's massive family of optos vary in speed allowing maximum opportunity to engineers worldwide.

All devices are performance guaranteed between -20°C and +80°C and have completed rigorous testing. The Company's customers can be assured of our commitment to stringent quality, reliability and inspection standards, as demonstrated by our existing approvals. Other customer specific options can also be offered.

FEATURES

- Performance guaranteed over -55°C to +125°C temperature range
- Manufactured and tested in BS9000 and CECC20000 approved premises
- High current transfer ratio
- 1500V electrical isolation

Isocom Ltd reserves the right to change the details on this specification without notice. Please consult Isocom Ltd prior to use. Isocom Ltd cannot accept liability for any errors or omissions.

For sales enquiries, or further information, please contact our sales office at:

Isocom Ltd, Hutton Close, Crowther Industrial Estate, District 3, Washington, NE38 0AH

Tel: +44 0191 4166 546 Fax: +44 0191 4155 055 Email Isocom@isocomoptocouplers.com

Or go to the Isocom Website @: [Http://www.isocom.uk.com](http://www.isocom.uk.com)

ABSOLUTE MAXIMUM RATINGS

Storage Temperature	-65°C to +100°C
Operating Temperature	-55°C to +80°C
Lead Soldering Temperature	260°C 1.6mm from case for 10S
Input-to-Output Isolation Voltage	↑7500VDC

Input Diode

Forward DC Current	50mA	
Reverse DC Voltage	7V	
Peak forward Current	1.5mA	≤ 10μS duration
Power Dissipation	100mW	Derate linearly above 100°C at 1.6W/°C.

Output Transistor

Collector-Emitter Voltage	50V	BV_{CEO}
Emitter-Collector Voltage	7V	BV_{ECO}
Collector-Base Voltage	70V	BV_{CBO} For
Collector Current	50mA	
Collector Current	100mA	t = 1mS
Power Dissipation	100mW	For . Derate linearly above 100°C at 1.4W/°C

PACKAGES

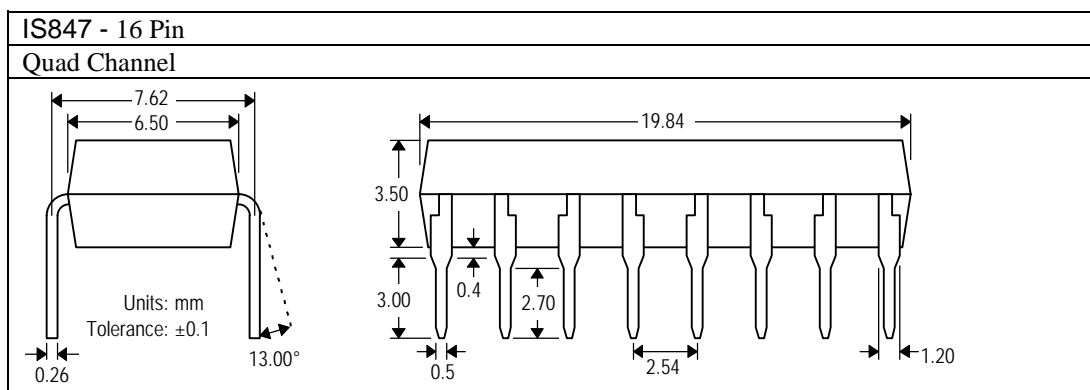
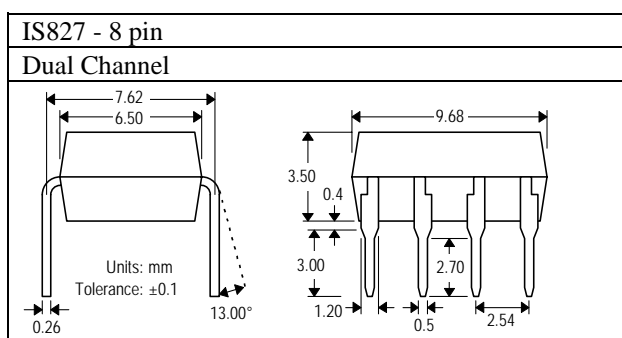
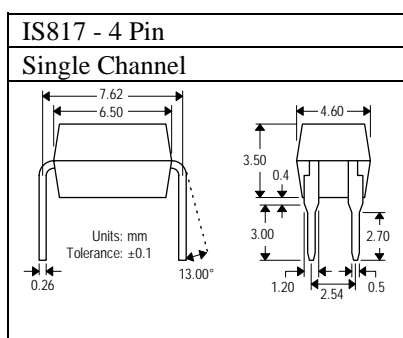

SMD and GULL WING are available for all the above.

Isocom Ltd reserves the right to change the details on this specification without notice. Please consult Isocom Ltd prior to use. Isocom Ltd cannot accept liability for any errors or omissions.

For sales enquiries, or further information, please contact our sales office at:

Isocom Ltd, Hutton Close, Crowther Industrial Estate, District 3, Washington, NE38 0AH

Tel: +44 0191 4166 546 Fax: +44 0191 4155 055 Email Isocom@isocomptocouplers.com

Or go to the Isocom Website @: [Http://www.isocom.uk.com](http://www.isocom.uk.com)

ELECTRICAL CHARACTERISTICS

$T_A = 25^\circ\text{C}$ U.O.S. (each channel where appropriate).

Input Diode Electrical Characteristics

Parameter	Symbol	Test Conditions	Device	Min	Typ	Max	Units
Forward Voltage	V_F	$I_F = 10\text{mA}$		0.7	1.18	1.4	V
		$I_F = 10\text{mA}, T_A = 125^\circ\text{C}$		0.7	1.10	1.2	
		$I_F = 10\text{mA}, T_A = -55^\circ\text{C}$		0.7	1.29	1.5	
Reverse Breakdown Voltage	V_R	$I_R = 0.1\text{mA}$		7	-	-	V
Reverse Current	I_R	$V_R = 3\text{V}$		-	-	100	μA
Capacitance	C_{IN}	$V = 0, f = 1\text{MHz}$		-	25	-	pF

Output Detector Electrical Characteristics

Collector-Emitter Breakdown Voltage (See note 1 below)	BV_{CEO}	$I_C = 1\text{mA}$		50	-	-	V
Collector-Base Breakdown Voltage (See note 1 below)	BV_{CBO}	$I_B = 0.1\text{mA}$		70	-	-	V
Emitter-Collector Breakdown Voltage	BV_{ECO}	$I_E = 0.1\text{mA}$		7	-	-	V
Emitter-Base Breakdown Voltage	BV_{EBO}	$I_B = 0.1\text{mA}$		5	-	-	V
Collector-Emitter Leakage Current	I_{CEO}	$V_{CE} = 20\text{V}, I_F = 0$		-	6	100	nA
		$V_{CE} = 20\text{V}, I_F = 0, T_A = 125^\circ\text{C}$		-	8	100	μA

Coupled Electrical Characteristics

DC Current Transfer Ratio (See note 3)	I_C/I_F	$I_F = 10\text{mA}, V_{CE} = 5\text{V}$		50	-	600	%
		$I_F = 10\text{mA}, V_{CE} = 5\text{V}, T_A = 125^\circ\text{C}$		50	-	600	
		$I_F = 10\text{mA}, V_{CE} = 5\text{V}, T_A = -55^\circ\text{C}$		60	-	600	
		$I_F = 1\text{mA}, V_{CE} = 5\text{V}$		40	-	600	
Collector-Emitter Saturation Voltage	$V_{CE}(\text{Sat})$	$I_F = 10\text{mA}, I_C = 2.5\text{mA}$		-	-	0.3	V
Input to Output Capacitance	C_{IO}	$V_{IO} = 0, f = 1\text{mhz}$ (See note 2 below)		-	2	5	pF
Input to Output Resistance	R_{IO}	$V_{IO} = 500\text{V}$ (See note 2 below)		-	10^{11}	-	\downarrow
Isolation Voltage	V_{IO}	(See note 2 below)		7500	-	-	VDC
Delay Time	td	$V_{CC} = 5\text{V}, I_C = 2\text{mA}$		-	3.3	7	μS
Rise Time	tr	$R_L = 100\text{Ohms}$		-	5.0	8	μS
Storage Time	ts			-	0.4	0.8	μS
Fall Time	tf			-	4.8	8	μS
Turn-on Time	t_{on}	$V_{CC} = 5\text{V}, I_f = 5\text{mA}$		-	4	15	μS
Turn-off Time	t_{off}	$R_L = 1\text{KOhms}$		-	8	20	μS

Notes

- BV_{CEO} and BV_{CBO} can be selected to suit customer specifications.
- Measured between input when leads 1, 2 and 3 are shorted together, and output when leads 4, 5 and 6 are shorted together.
- A higher CTR can be selected to suit customer specification as a standard part.

Isocom Ltd reserves the right to change the details on this specification without notice. Please consult Isocom Ltd prior to use.

Isocom Ltd cannot accept liability for any errors or omissions.

For sales enquiries, or further information, please contact our sales office at:

Isocom Ltd, Hutton Close, Crowther Industrial Estate, District 3, Washington, NE38 0AH

Tel: +44 0191 4166 546 Fax: +44 0191 4155 055 Email Isocom@isocomoptocouplers.com

Or go to the Isocom Website @: [Http://www.isocom.uk.com](http://www.isocom.uk.com)

ELECTRICAL CHARACTERISTICS

CURRENT TRANSFER RATIO -v- TEMPERATURE
 $I_F=10\text{mA}$ $V_{CE}=5\text{V}$ $T_A=25^\circ\text{C}$

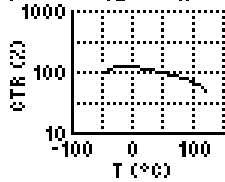

CTR vs Temperature

CURRENT TRANSFER RATIO -v- DIODE FORWARD CURRENT
 $V_{CE}=5\text{V}$ $T_A=25^\circ\text{C}$

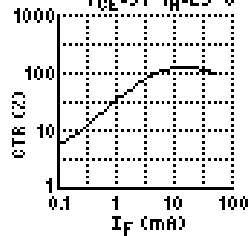

CTR vs Diode Forward Current

DIODE FORWARD VOLTAGE (Typ) -v- FORWARD CURRENT

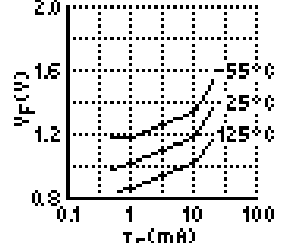

Forward Voltage (Typ) of the Diode vs Forward Current

COLLECTOR-EMITTER SATURATION VOLTAGE -v- AMBIENT TEMPERATURE
 $I_F=15\text{mA}$ $I_C=2\text{mA}$

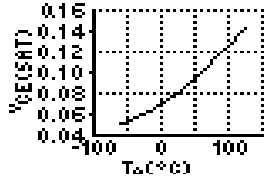

Collector-Emitter Saturation Voltage vs Ambient Temperature

COLLECTOR DARK CURRENT -v- AMBIENT TEMPERATURE
 $V_{CE}=20\text{V}$

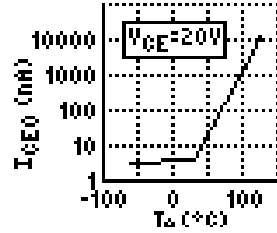

Collector Dark Current vs Ambient Temperature

COLLECTOR-EMITTER VOLTAGE -v- COLLECTOR CURRENT
 $T_A=25^\circ\text{C}$

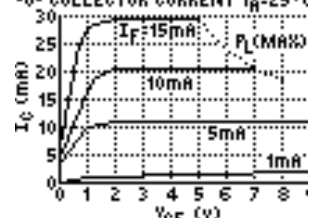

Collector Current vs Collector-Emitter Voltage

Isocom Ltd reserves the right to change the details on this specification without notice. Please consult Isocom Ltd prior to use.

Isocom Ltd cannot accept liability for any errors or omissions.

For sales enquiries, or further information, please contact our sales office at:

Isocom Ltd, Hutton Close, Crowther Industrial Estate, District 3, Washington, NE38 0AH

Tel: +44 0191 4166 546 Fax: +44 0191 4155 055 Email Isocom@isocomptocouplers.com

Or go to the Isocom Website @: [Http://www.isocom.uk.com](http://www.isocom.uk.com)