

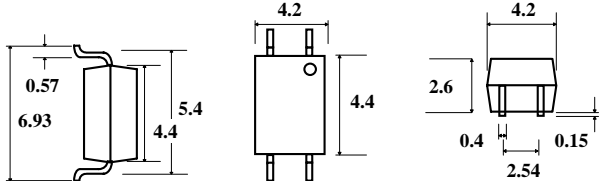

# IS357 TRANSISTOR OPTOCOUPERS

**ISOCOM**<sup>®</sup> LTD

PACKAGES	CIRCUIT
	

## DESCRIPTION

The IS357 is a single channel device suitable for use in vending machines, programmable controllers and copiers. The device incorporates an infra red LED and a phototransistor detector.

Isocom Ltd supplies a multitude of plastic optocouplers for all applications varying from standard transistor optos through to Darlington and Schmitt Trigger devices. It's massive family of optos vary in speed allowing maximum opportunity to engineers worldwide.

All devices are performance guaranteed between -20°C and +80°C and have completed rigorous testing. The Company's customers can be assured of our commitment to stringent quality, reliability and inspection standards, as demonstrated by our existing approvals. Other customer specific options can also be offered.

## FEATURES

- 3750V Isolation
- Subminiature Type
- Opaque Type Mini-Flat Pack
- Current Transfer Ratio (Min 50% @  $I_F = 5\text{mA}$ ,  $V_{CE} = 5\text{V}$ )

Isocom Ltd reserves the right to change the details on this specification without notice. Please consult Isocom Ltd prior to use.

Isocom Ltd cannot accept liability for any errors or omissions.

For sales enquiries, or further information, please contact our sales office at:

Isocom Ltd, Hutton Close, Crowther Industrial Estate, District 3, Washington, NE38 0AH

Tel: +44 0191 4166 546 Fax: +44 0191 4155 055 Email [Isocom@isocomoptocouplers.com](mailto:Isocom@isocomoptocouplers.com)

Or go to the Isocom Website @: [Http://www.isocom.uk.com](http://www.isocom.uk.com)

## ABSOLUTE MAXIMUM RATINGS

Storage Temperature	-40°C to +125°C
Operating Temperature	-30°C to +100°C
Lead Soldering Temperature	260°C 1.6mm from case for 10S
Input-to-Output Isolation Voltage	3750VDC

### Input Diode

Forward DC Current	50mA	
Peak forward Current	1.0A	
Reverse Voltage	6V	
Power Dissipation	70mW	

### Output Transistor

Collector-Emitter Voltage	60V	$BV_{CEO}$
Emitter-Collector voltage	5V	$BV_{ECO}$
Collector-Current	50mA	$I_C$
CollectorPower Dissipation	150mW	$P_C$

### Package

Total Power Dissipation	170mW	$P_{tot}$
-------------------------	-------	-----------

## ELECTRICAL CHARACTERISTICS

$T_A = 25^\circ\text{C}$  U.O.S. (each channel where appropriate).

### Input Diode Electrical Characteristics

Parameter	Symbol	Test Conditions	Device	Min	Typ	Max	Units
Forward Voltage	$V_F$	$I_F = 20\text{mA}$			1.2	1.4	V
Reverse Current	$I_R$	$V_R = 4\text{V}$				10	$\mu\text{A}$

### Output Detector Electrical Characteristics

Terminal Capacitance	$C_t$	$V = 0, f = 1\text{KHz}$			30	250	pF
Collector-emitter Dark Current	$I_{CEO}$	$V_{CE} = 20\text{V}, I_F = 0$				0.1	$\mu\text{A}$
Collector-Emitter Breakdown Voltage	$BV_{CEO}$	$I_C = 0.1\text{mA}, I_F = 0$		60	-	-	V
Emitter-Collector breakdown Voltage	$BV_{ECO}$	$I_E = 100\mu\text{A}, I_F = 0$		5			V

### Coupled Electrical Characteristics

Current Transfer ratio	CTR	$I_F = 5\text{mA}, V_{CE} = 5\text{V}$		50		600	%
Collector-Emitter saturation voltage	$V_{CE(sat)}$	$I_F = \pm 20\text{mA}, I_C = 1\text{mA}$			0.1	0.3	V
Isolation Resistance	$R_{ISO}$	DC= 500V, 40 to 60% RH		$5 \times 10^{10}$	$5 \times 10^{11}$		$\Omega$
Floating Capacitance	$C_f$	$V = 0, f = 1\text{Mhz}$			0.6	1.0	pF
Responce time (Rise)	$t_r$	$V_{CC} = 2\text{V}, I_C = 2\text{mA}, R_L = 100\Omega$			5	20	$\mu\text{S}$
Responce time (Fall)	$t_f$				4	20	$\mu\text{S}$
Input-to-Output Isolation				3750			V

Isocom Ltd reserves the right to change the details on this specification without notice. Please consult Isocom Ltd prior to use.

Isocom Ltd cannot accept liability for any errors or omissions.

For sales enquiries, or further information, please contact our sales office at:

Isocom Ltd, Hutton Close, Crowther Industrial Estate, District 3, Washington, NE38 0AH

Tel: +44 0191 4166 546 Fax: +44 0191 4155 055 Email [Isocom@isocomptocouplers.com](mailto:Isocom@isocomptocouplers.com)

Or go to the Isocom Website @: [Http://www.isocom.uk.com](http://www.isocom.uk.com)