

4N29,30,31,32,33

High Reliability Optically Coupled Isolator

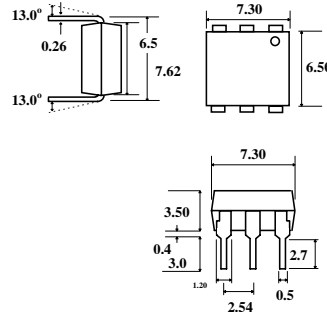

Isocom Ltd supplies high reliability devices for applications requiring an operating temperature range of -55°C to $+100^{\circ}\text{C}$ (e.g. military applications).

Devices supplied are approved to BS9400, and have completed rigorous testing. Various high reliability test options are offered.

As a manufacturer of high reliability optocouplers, the Isocom Ltd manufacturing plant in the North East of England has site approval to BS9000 (registration number 1294/M) and CECC20000 (registration number M/1084/CECC/UK) issued by the British Standards Institution.

Together with CECC, BS9000 is a preferred standard for use in European military projects. Consequently, Isocom Ltd's approved devices are listed in the CECC "MUAHAG" preferred products list.

The BS9000 approval is also recognised as meeting the equivalent criteria to those required by BS5750/IS09000/EN29000.

The Company's customers can be assured of our commitment to stringent quality, reliability and inspection standards, as demonstrated by our existing approvals. Other customer specific options can also be offered.

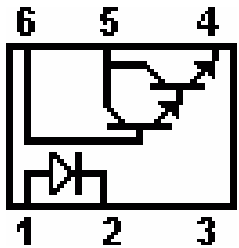
Features	Applications	
6 Pin D.I.L. Package	System test equipment	
High Radiance LED	Medical instruments	
Silicon phototransistor	Switch mode power supplies	
High Current transfer ratio at low diode current drive	Signal transmission between	
1.5kVDC Electrical Isolation	Circuits of different potential and impedance	
Low input current		

Isocom Ltd reserves the right to change the details on this specification without notice. Please consult Isocom Ltd prior to use.

Isocom Ltd cannot accept liability for any errors or omissions.

For sales enquiries, or further information, please contact our sales office at:

Isocom Ltd, Hutton Close, Crowther Industrial Estate, District 3, Washington, NE38 0AH

Tel: +44 0191 4166 546 Fax: +44 0191 4155 055 Email Isocom@isocomoptocouplers.com

Or go to the Isocom Website @: [Http://www.isocom.uk.com](http://www.isocom.uk.com)

Description

The 4N29, 4N30, 4N31, 4N32 and 4N33 are optically coupled isolators consisting of a Gallium Arsenide infrared emitter and a silicon photo darlington sensor. Switching can be accomplished while maintaining a high degree of isolation between driving and load circuits. They can be used to replace reed and mercury relays with advantages of long life, high speed switching and elimination of magnetic fields.

Absolute Maximum Ratings

Storage temperature	-55°C to +150°C
Operating temperature	-55°C to +100°C
Input-to-output isolation voltage	25,000VDC (4N29, 4N32) 15,000VDC (4N30, 4N31, 4N33)

Input Diode

Forward DC current	60mA
Reverse DC voltage	3V
Peak forward current	3A
Power Dissipation	100mW

Output Phototransistor

Collector-emitter voltage BV_{CEO}	30V
Emitter-collector voltage BV_{ECO}	7V
Power Dissipation	150mW

Total Power Dissipation	250mW
-------------------------	-------

Electrical Characteristics ($T_A = -55$ to 125°C U.O.S) *All typical values at $T_A = 25^\circ\text{C}$

parameter	symbol	Test Conditions	min	*typ	max	Units
Forward voltage	V_F	$I_F = 10\text{mA}$			1.5	V
Reverse Current	I_R	$V_R = 3.0\text{V}$			100	μA
Reverse Breakdown Voltage	V_R	$I_R = 100\mu\text{A}$	3.0			V
Collector-emitter breakdown voltage	BV_{CEO}	$I_C = 1\text{mA}$	30			V
Emitter-collector voltage	BV_{ECO}	$I_E = 100\mu\text{A}$	5			V
Collector-emitter leakage current	I_{CEO}	$V_{CE} = 10\text{V}, I_B = 0$			100	nA
Collector Emitter Capacitance	C_{CE}	$V_{CE} = 0$		10		pf
coupled						
DC Current Transfer Ratio 4N31	I_C/I_F	$I_F = 10\text{mA}, V_{CE} = 10\text{V}$	50			mA
4N29, 4N30		$I_B = 0$	100			mA
4N32, 4N33			500			mA
Input-to-output Isolation Resistance	R_{IO}	$V_{IO} = 500\text{V},$ (Note 1)	10^{11}			Ω
Collector-Emitter Saturation Voltage	$V_{CE(sat)}$	$I_F = 8\text{mA}, I_C = 2\text{mA},$ $I_B = 0$				V
4N29, 4N30, 4N32, 4N33		$V_{CC} = 10\text{V}, I_{CC} 2\text{mA}$		1		V
4N31				1.2		V
Turn-on-time	T on	$I_C = 50\text{mA},$ $V_{CC} = 10\text{V}$			5	μs
Turn-off-time	T off	$I_F = 200\text{mA P.W.} =$ 1.0m.s.				
4N29, 4N30, 4N31					40	μs
4N32, 4N33					100	μs
Input-to-output Isolation Voltage						
4N29, 4N32		(note 1)	2500			VDC
4N30, 4N31, 4N33			1500			VDC

Note 1. Measured with input leads shorted together and output leads shorted together